

WIRE GRIND 2500

AUTOMATIC WIRE GRINDING MACHINE



Description

The WireGrind 2500 was developed for grinding conical/cylindrical wires. It can be used to manufacture the tool for the unique honing process, the tapered wire used on the **FINE HONE 600** and **acuwire-L**.

Wire Sketch

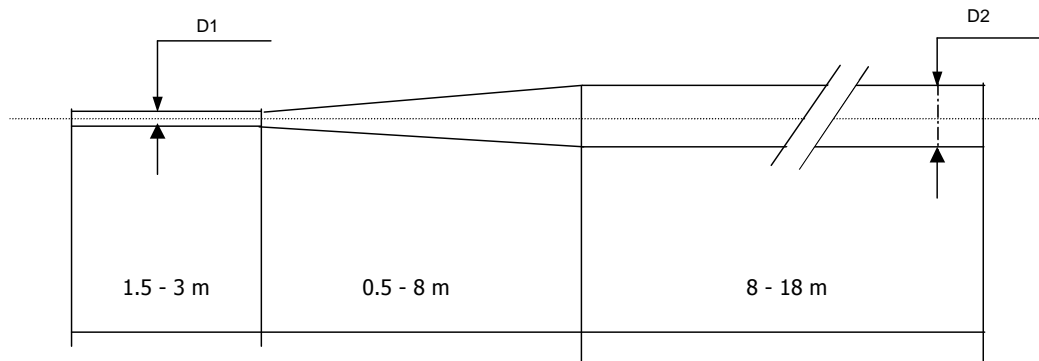

Remark: Longer or shorter wires can also be grinded!

Technical data

Range of O.D. to be processed	0.30 – 2.00mm
Cooling system	Integrated
Air pressure	min. 4 bar
Dimensions (LxHxD)	1250x1000x1250mm
Net Weight	250Kg
Command power	24 VDC
Supply voltage	220 VAC/50-60Hz

All technical specifications and illustrations are without obligation and subject to change without notice.